

H 21 TX

Telescopic boom

The Haulotte® advantages

- Standard foam filled tyres.
- 4 wheel drive.
- Length : 9.1 / 29 ft 10 in.
- Hydraulic differential lock for demanding rough terrain conditions.
- Work platform overload limiter increases safety.
- Large & robust slewing ring
- Simultaneous proportional controls for all movements.
- Side mounted engine for easy access & maintenance.
- Improved productivity through fast boom movement speeds.
- Robust, reliable, easy to maintain design.

STANDARD FEATURES

- 62 ft (18.86 m) platform height
- 5° tilt alarm
- 180° hydraulic platform basket rotation
- Silent pack Hatz diesel engine
- Free wheeling device
- Electric emergency lowering system
- Safe use in winds up to 28 mph (45 km/h)
- Simple uncomplicated operational controls
- Turret slewing lock rod
- Hourmeter
- Towing hooks / lifting eyes
- 2 hooks for safety harness in platform

OPTIONS & ACCESSORIES

- Large platform (2.3 m x 0.8 m / 91 in X 32 in)
- Rotating beacon
- Catalytic exhaust
- Working light
- Travel alarm
- Power line to cage
- Encoded starting device
- Hot countries kit
- On-board generator 3,3 kW
- Capacity of 794 lb (360kg) with a wind up to 37 mph (60km/h). (Weight of the machine : 27871 lb /12640kg)

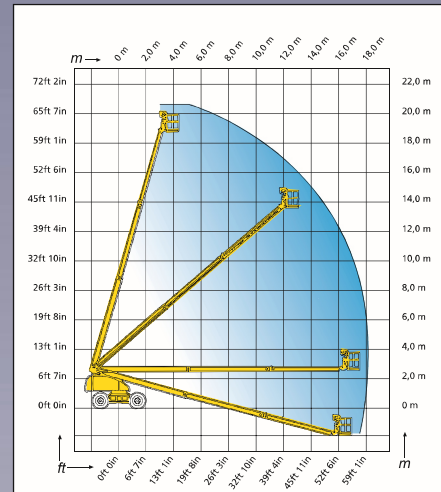
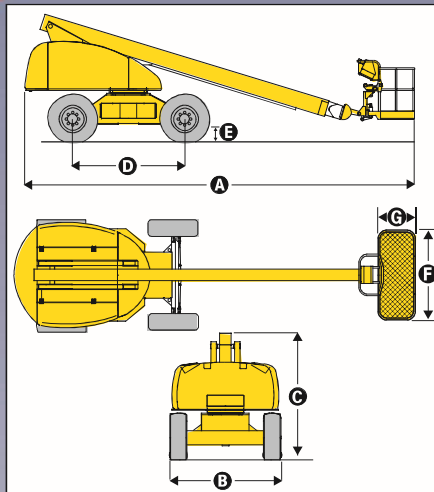

SPECIFICATIONS

Working Height	68 ft 3 in	20.8 m
Platform Height	61 ft 8 in	18.8 m
Horizontal Reach	56 ft 3 in	17.2 m
Platform Capacity	507 lb	230 kg
A Length	29 ft 10 in	9.1m
B Width	8 ft 2 in	2.48 m
C Stowed Height	9 ft 5 in	2.86 m
D Wheelbase	8 ft 2 in	2.49 m
E Ground clearance	13 in	35 cm
F x G Platform size	71 in x 32 in	1.8 m x 0.8 m
Tailswing	42 in	1.1 m
Drive speed	0.9 - 3.1 mph	1.5 - 5.0 km/h
Outside turning radius	20 ft 2 in	6.15 m
Turntable Rotation - Continuous	360°	360°
Platform Rotation	180°	180°
Power source	Diesel 43.6 hp / 32.1 KW	
Controls	12 V proportional	
Gradeability	40%	
Tyres (Foam Filled)	15 R 22	
Hydraulic tank	40 gallons	150 l
Fuel tank	40 gallons	150 l
Weight	25 909 lb	11 750 kg

AS 1418.10

